



# Gx-Series Thermal Ink Jet Printers

Clean. Clear. Coding.



Domino. Do more.

# Trusted thermal ink jet coding solutions

Gx-Series printing solutions are versatile, easy to integrate, easy to operate - the perfect fit on many printing applications and substrates. With latest networking technology and producing graphic code quality, the Gx-Series is ideal, not only for batch and date coding, but also for complex code formats, check weighing, and track & trace applications across FMCG industries.

If you are looking for a coding solution that is designed for high resolution printing at high line speeds with complete reliability, Gx-Series thermal ink jet (TIJ) printers can meet your needs.



## Life sciences

Legislative requirements call for unique item level identification. Gx-Series printers ensure coding in compliance with pharmaceutical regulations (e.g. EU FMD, US DQSA) according to GSI standards and can be included into a 21 CFR Part II validated system.



## Electronics and industrial

Gx-Series prints lasting, rub and scratch resistant codes, logos and graphics on electronic components, metal, aluminium, or PCBs. Rapid dry times and good adhesion deliver optimum performance on fast paced production lines.



## Fast moving consumer goods

For the variety of coding requirements within the FMCG sectors, Domino has developed an ink range that is suitable for all packaging levels – from flexible films to porous shelf ready packaging and shipping boxes.



# Ready for the future

## Easy to integrate

- ◆ Small footprint: easy printhead integration and remote controller mounting.
- ◆ Track & trace and item level serialisation via Dynamark protocol: 21 CFR Part 11 compliant, audit trail with comprehensive user administration, validation documentation available.
- ◆ The **Gx**-OEM controller model is optimised for control cabinet integration.

## Easy to operate

- ◆ Effortlessly run printers through the feature-rich touchscreen interface or remotely via web browser. Create and edit labels directly on board.
- ◆ Automatic cartridge recognition and ink parameter setting.
- ◆ Continuous Operation: for uninterrupted production the **AutoSwap** functionality enables cartridge change while printing. A Bulk Ink system is available for long-run operation without the need for any operator intervention.
- ◆ Multiple printhead capability for dual-sided box coding, separate line coding and stitched printheads for increased message heights.



## Easy to network

- ◆ Fieldbus options like EtherCAT and Ethernet/IP: fast data transfer; integration with PLCs and precise synchronisation for motion control systems.
- ◆ External data capture (EDC) directly onto the controller for promotional coding or check weigher applications.
- ◆ Remote controlling Gx-Series printers is simple using the web browser interface.



## Clean. Clear. Coding.

- ◆ Graphic printing quality, on paper, card, plastic, metal, and many other materials.
- ◆ Flexible label design: text, counters, clocks, graphics, logos, barcodes can all be included on the same label.
- ◆ Grade A code readability (ISO 15415) using Domino's inks on high density datamatrix codes. (Substrate dependent)





## Gx-Series printheads

- ◆ Versatile printhead variants to support wide range of applications:
  - Standard range:** 12.7mm high and includes a compact printhead option.
  - EXT range:** up to 26.1mm per printhead for larger codes, all without the need to stitch.
  - OPT range:** 13.5mm codes with a higher throw distance (up to 10mm) for special applications.
- ◆ Flexible printhead configurations:
  - Up to 4-printhead operation for multiple side coding, separate lines coding or increased message height (printhead variant dependent).
  - Flexible connector options (front, back and top) on all variants.
- ◆ LED status signals show the print status, e.g. which cartridge needs changing.
- ◆ Maintenance-free: exchange of the ink cartridge replaces all printer wear parts.
- ◆ Error-free coding with automatic ink parameter setting.

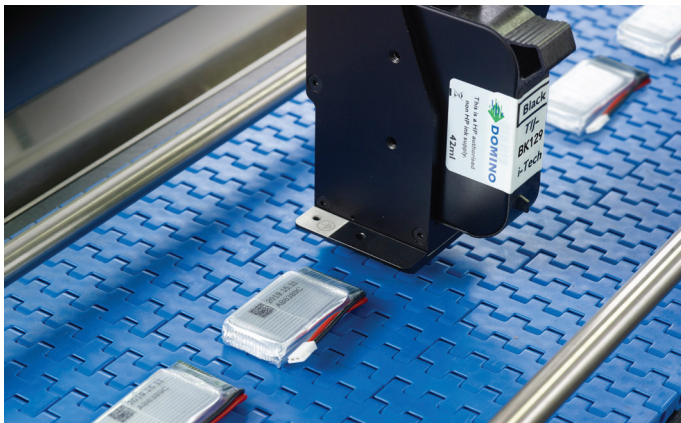

## User interface

Domino offers a range of interfaces on the printer, on a PC and directly to our Cloud based dashboards.

- ◆ Easy operation using the **QuickStep** interface on the touch screen or via web browser on your HMI.
- ◆ Connecting to **Domino Cloud** gives you 24/7 visibility of the printer's performance and utilisation, allowing you to drive overall equipment effectiveness (OEE) and maximise your profitability.
- ◆ User access levels can be defined to ensure safe handling.
- ◆ Label creation and editing are simple using the **QuickStep** Label Creator or our PC-based design software.
- ◆ Coding Automation solutions to populate data directly from a database and control changeovers from your ERP or MES system.



## Built to fit

### Gx150i

Batch, date & time, barcodes using 1 or 2 printheads; serialisation option.



### Gx350i

Controls up to 4 printheads, IP64 rated controller for dusty or wet environments, fieldbus option.



### Gx-OEM

Seamlessly integrates with production machinery, controls up to 4 printheads, fieldbus option.



# Domino – we do more

## Domino inks

We develop TIJ inks that address our customers' needs and comply to the highest industry standards. Drawing on years of ink development expertise our TIJ inks deliver clear, durable codes onto a wide range of substrates.

- ◆ Rapid dry time and good adhesion on flexible films: line speeds up to 300m/min.
- ◆ Long decap times ensure consistent code quality and maximised uptime.
- ◆ EuPIA GMP compliant inks available for food packaging applications.
- ◆ Codes that last: independently proven lightfastness, adhesion, rub, and scratch resistance.
- ◆ Easy installation: distance printhead to substrate up to 4mm with the standard head and 10mm with the OPT printhead.
- ◆ Pin-sharp codes, logos, and graphics complement the overall brand appearance.



## Technology talk

- ◆ TIJ is a digital coding technology that uses electrical heat to eject ink droplets and apply them to a substrate.
- ◆ It is particularly clean and easy to use: the simple replacement of the ink cartridge is the only maintenance required.
- ◆ Print with graphic quality up to 600x600dpi with the standard and compact printheads, and 600x300dpi with the EXT and OPT printheads.
- ◆ The printheads do not touch the product, but need to be guided closely to it with only a few mm distance.



## A complete solution

Our services are designed to provide operational insight so you can eliminate downtime and maximise production efficiency.



### Operational support

An outstanding level of care, wherever you are. Our **SafeGuard** packages provide high-quality, on-site assistance and AR-enabled remote guidance from our engineers. **SafeGuard** helps to ensure we can be with you when you need us most.

### Automatic code inspection

Ensure every code that leaves your factory is present and correct, and free up operator time. With the R-Series, Domino's range of vision control systems, you can automate your code inspection to validate code presence, placement, and readability.

### Control software

Minimise errors using Domino's **QuickDesign** software. Control your product codes from a central location and streamline product changeovers. **QuickDesign** uses standard communication protocols and can be integrated into existing ERP systems.

### Smart production

Gain operational insight by connecting your printer to **Domino Cloud**. Obtain production analytics dashboards and receive system error alerts. **Domino Cloud** provides you with the information you need to run your operations more efficiently.

## Technical specification

	Gx150i	Gx350i	Gx-OEM
<b>Controller specifications</b>			
Controller dimensions	Height: 75mm Width: 224mm Depth: 156.5mm Weight: 1.55kg	Height: 123.9mm Width: 322.4mm Depth: 250.7mm Weight: 6.4kg	Height: 64mm Width: 200mm Depth: 159.2mm Weight: 0.692kg
<b>Printhead specification</b>			
Printhead dimensions (TOP variant including connector)	Standard printhead: height 162mm, width 28.5mm, depth 52.9mm, weight 0.22kg Compact printhead: height 104.5mm, width 28.5mm, depth 111.1mm, weight 0.29kg EXT printhead: height 162mm, width 29.7mm, depth 68.9mm, weight 0.27kg OPT printhead: height 158mm, width 35.7mm, depth 78mm, weight 0.31kg		
Printhead cables	1.5, 3, 6, 12 or 25m		
Printheads per controller	Up to 2 printheads for increased message height or individual printing on 2 different print positions	Up to 4 printheads for increased message height or individual printing on up to 4 different print positions	
Print height	Standard printhead: 1 printhead 12.7mm, 2 printheads 25.4mm Compact printhead: 1 printhead 12.7mm, 2 printheads 25.4mm EXT printhead: 1 printhead 26.1mm, 2 printheads 52.2mm OPT printhead: 1 printhead 13.5mm, 2 printheads 27.1mm	Standard printhead: 1 printhead 12.7mm, 2 printheads 25.4mm 3 printheads 38.1mm, 4 printheads 50.8mm Compact printhead: 1 printhead 12.7mm, 2 printheads 25.4mm 3 printheads 38.1mm, 4 printheads 50.8mm EXT printhead: 1 printhead 26.1mm, 2 printheads 52.2mm, 3 printheads 78.2mm, 4 printheads 104.3mm OPT printhead: 1 printhead 13.5mm, 2 printheads 27.1mm, 3 printheads 40.6mm, 4 printheads 54.2mm	Standard printhead: 1 printhead 12.7mm, 2 printheads 25.4mm 3 printheads 38.1mm, 4 printheads 50.8mm Compact printhead: 1 printhead 12.7mm, 2 printheads 25.4mm 3 printheads 38.1mm, 4 printheads 50.8mm EXT printhead: 1 printhead 26.1mm, 2 printheads 52.2mm, 3 printheads 78.2mm, 4 printheads 104.3mm OPT printhead: 1 printhead 13.5mm, 2 printheads 27.1mm, 3 printheads 40.6mm, 4 printheads 54.2mm
Print speed and horizontal resolution*	Standard, Compact and EXT printhead: up to 300m/min at 60dpi to 30m/min at 600dpi OPT printhead: high speed mode enabled up to 228m/min at 60dpi to 22m/min at 600 dpi, high speed mode disabled up to 150m/min at 60dpi to 15m/min at 600 dpi		
<b>Ownership specification</b>			
External connection options	1 encoder, I/Os for beacons, product detects or other, 2 USBs (type A), RS232C, 2x LAN	2 encoders, I/Os for beacons, product detects or other, 2 USBs (type A), RS232C, 2x LAN	2 encoders, I/Os for beacons, product detects or other, 2 USBs (type A), RS232C, 2x LAN
Power connector	6mm DC power jack	3-way plug	S2C 3.5mm, 4-way, terminal block
Electrical supply	Input: 100-240 V AC, 50-60 Hz, 2 A	100-240 V AC, 50-60 Hz, 3.5 A	24V DC, 4 A
Controller operating temperature	0° - 40°C (32° - 104°F)	0° - 45°C (32° - 113°F)	
Operating relative humidity	20 - 80% RH (non condensing, 10°C increase per hour)		
Controller finish	Stainless steel		
Communication	Ethernet / Dynamark protocol, EDC (serial, TCP, USB)	Ethernet / Dynamark protocol, EDC (serial, TCP, USB) optional: fieldbus protocols	
User interface	<b>QuickStep</b> via 7" touch screen or customer HMI	<b>QuickStep</b> via 10" touch screen or customer HMI	<b>QuickStep</b> via customer HMI
Continuous operation options	Bulk Ink system for long-run operation, <b>AutoSwap</b> for uninterrupted production		
<b>Consumables</b>			
Inks**	A range of fast drying water and solvent based inks for porous and non-porous substrates, black, colours, and specialist inks		
i-Teckx features	Automatic ink cartridge detection, automatic ink parameter setting, automatic ink level recording		

\* Ink dependent \*\*This product has a Quality Management System that means that it will only work with Domino circuitry, and it uses dynamic security measures to block non-Domino circuitry from being used. From time to time updates to the circuitry will be issued by Domino to maintain the effectiveness of the Quality Management System

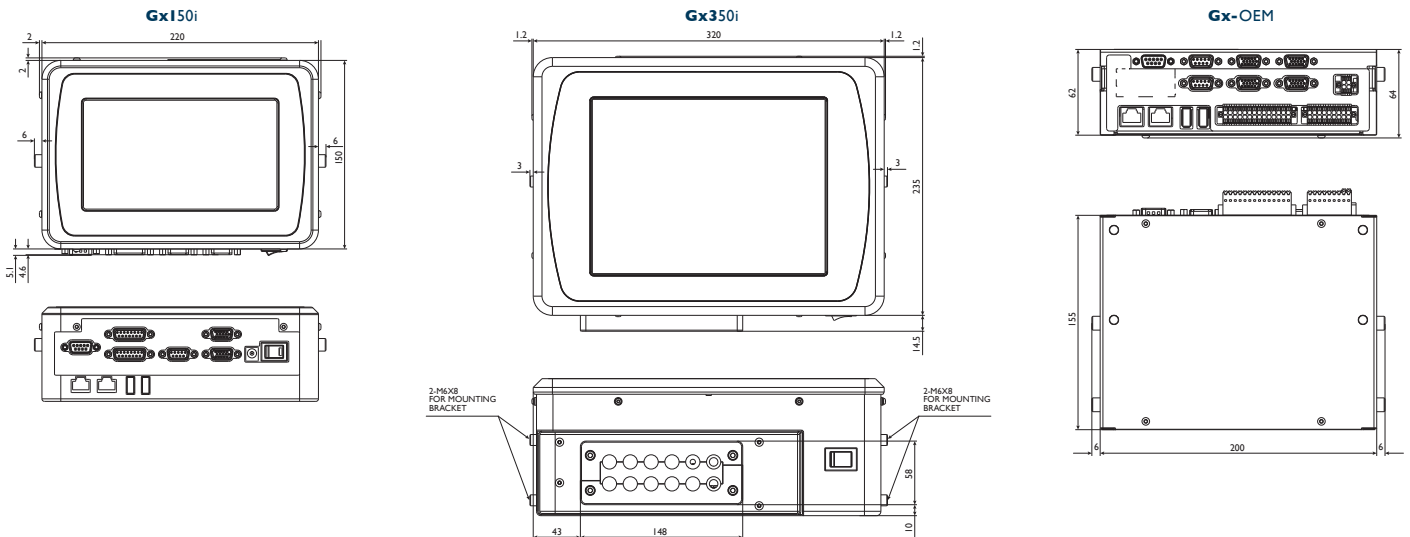

Standard printhead – Top connector

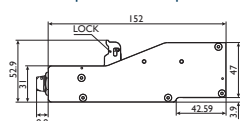

Compact printhead – Top connector

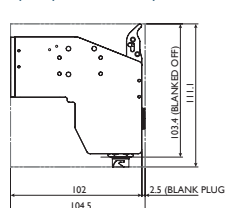

EXT printhead – Top connector

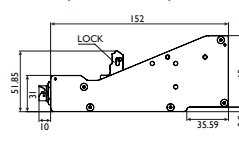

OPT printhead – Top connector

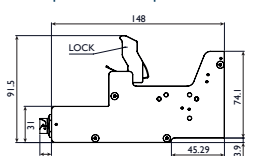

SCAN HERE

[www.domino-printing.com](http://www.domino-printing.com)

Domino Printech India LLP, 117, Sector - 8, IMT Manesar, Gurugram, Haryana, India - 122050